

日期/Date
档案员
Filing Clerk

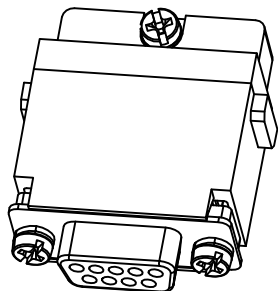
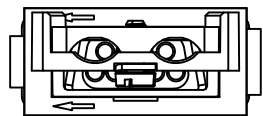
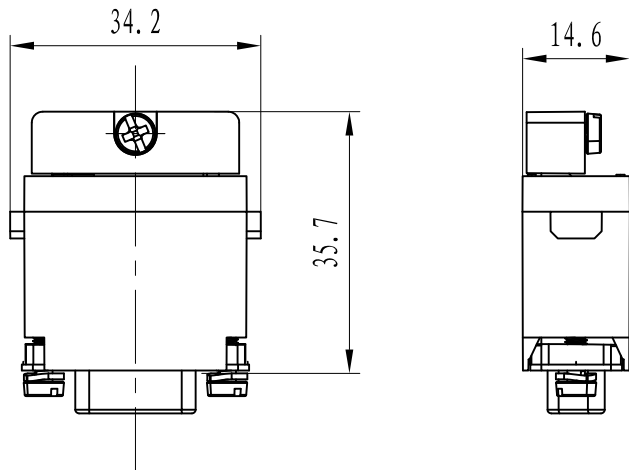

技术参数:

- 插芯:
- 插针数: 9
 - 额定电流: 5A
 - 额定电压: 50V
 - 额定脉冲电压: 0.8kV
 - 污染等级: 3
 - 绝缘阻抗: $\geq 10^{10}\Omega$
 - 材料: 聚碳酸酯
 - 颜色: RAL 7032 (浅灰色)
 - 温度范围: $-40^{\circ}\text{C} - +125^{\circ}\text{C}$
 - 依据UL 94的阻燃等级: V0
 - 可插拔次数: ≥ 500

插针:

- 接线方式: 冷压连接
- 材料: 铜合金
- 表面处理:
 - 镀银
 - 镀金
- 接触电阻: $\leq 3\text{m}\Omega$
- 线径范围: $0.09-0.82\text{mm}^2(28-18 \text{ AWG})$

Technical specification:

Insters:

- No. of contact: 9
 - Rated current: 5A
 - Rated voltage: 50V
 - Rated impulse voltage: 0.8kV
 - Pollution degree: 3
 - Insulation resistance: $\geq 10^{10}\Omega$
 - Material: polycarbonate
 - Colour: RAL 7032(light grey)
 - Temperature range: $-40^{\circ}\text{C} - +125^{\circ}\text{C}$
 - Flammability acc.to UL 94: V0
 - Mating cycles: ≥ 500
- Contacts:
- Terminal: Crimp terminal
 - Material: copper alloy
 - Surface:
 - hard-silver plated
 - hard-silver plated
 - Contact resistance: $\leq 3\text{m}\Omega$
 - Wire gauge: $0.09-0.82\text{mm}^2(28-18 \text{ AWG})$

						表面处理 Finish		-		图号 Drawing No.		-		
						材料 Material		-		产品代号 Part Code		HMDS2.2-009-FC		
标记 Mark	处数 Number	变更描述/Description			签名 Signature	日期 Date					产品料号 Part No.		1290090200102	
	姓名/Name	日期/Date		姓名/Name	日期/Date	比例 Scale	版本 REV.	重量 Weight	数量 Qty.	产品名称 Part Name		-		
绘图 Drawn	WL KANG	27.02.2017	标准化 Stand.	-	-	1:1	V1.0	30.5g	-					
审核 Checked	ZW WU	27.02.2017												
工艺 Process	-	-	批准 Approved	YY LUO	27.02.2017			All Dimensions in mm Original Size DIN A 4		厦门唯恩电气有限公司 XIAMEN WAIN ELECTRICAL CO.LTD				