

日期/Date	档案员 Filing Clerk	1	2	3	4	5	6
插针数 Contacts	电缆出口直径 Cable outlet	产品料号 Cable outlet	型号 Part Code	重量 Weight			
4(3+PE)	6-8 mm	1680037113001	7/8-M03-CCT/R-T-D8	86 g			
	8-10 mm	1680037113002	7/8-M03-CCT/R-T-D10	85 g			
	10-12 mm	1680037113003	7/8-M03-CCT/R-T-D12	84 g			

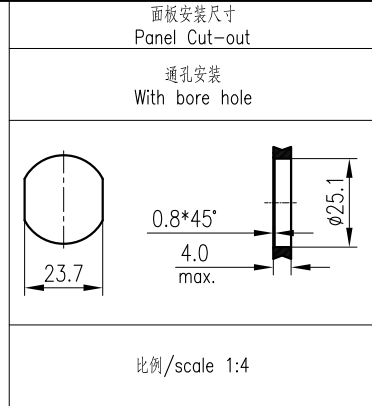

- 技术参数:
- 产品系列: 7/8
 - 插针数: 3(2+PE)
 - 插针分布: 2+PE
 - 插针直径(mm): $\phi 1.95$
 - 接线范围(mm²/AWG): Max1.5/16
 - 接线方式: 螺钉连接
 - 额定电流(40°C): 9A
 - 额定电压: 300V
 - 额定脉冲电压: 4KV
 - 过电压保护等级: III
 - 污染等级: 3
- 机械参数:
- 外壳材质: 铜合金, PA
 - 外壳表面处理: 镀镍
 - 插芯材质: TPU, PA
 - 密封材质: 氟橡胶
 - 温度范围: -25°C...+85°C
 - 电缆直径: $\phi 6-12$ mm
 - 插拔次数: >100
 - 防护等级: IP67

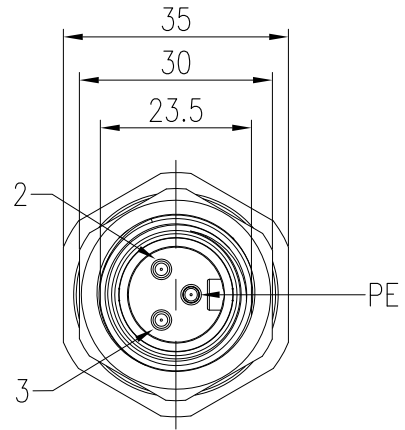
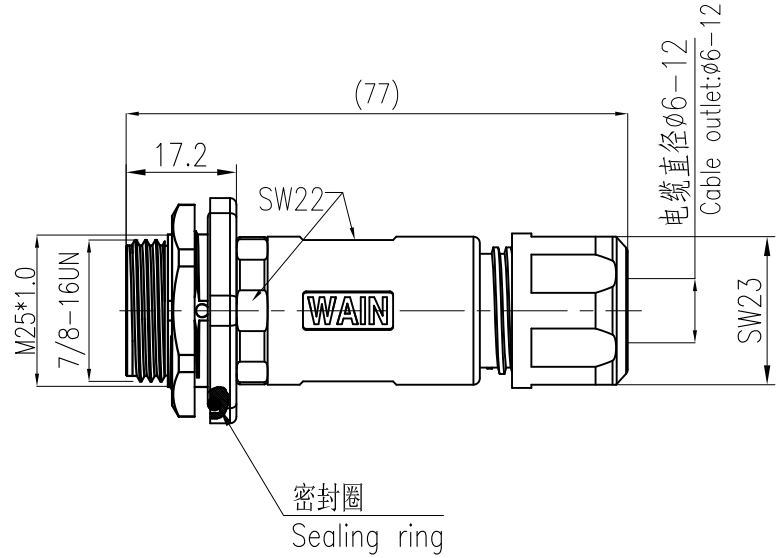

针位排布图
Contact arrangement

- Technical specification:
- Series: 7/8
 - Number of contacts: 3(2+PE)
 - Contact arrangement: 2+PE
 - Contact diameter(mm): $\phi 1.95$
 - Wire gauge(mm²/AWG): Max1.5/16
 - Terminal: Screw
 - Rated current(40°C): 9A
 - Rated voltage: 300V
 - Rated impulse voltage: 4KV
 - Overvoltage category: III
 - Pollution degree: 3
- Mechanical specification:
- Material of housing: CuZn, PA
 - Finish of housing: Nickel-plated
 - Material of Insert: TPU, PA
 - Material of sealing: FPM
 - Temperature range: -25°C...+85°C
 - Cable Outlet: $\phi 6-12$ mm
 - Mating cycles: >100
 - Degree of protection: IP67

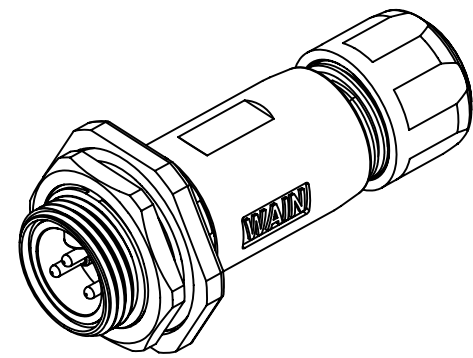

表面处理 Finish	-				图号 Drawing No.	-				
材料 Material	-				产品代号 Part Code	7/8-M03-CCT/R-T-DX				
比例 Scale	版本 REV.	重量 Weight	数量 Qty.	标记 Mark	处数 Number	变更描述/Description	姓名/Name	日期/Date	姓名/Name	日期/Date
1:1	V1.0	-	-	TC CHEN	11.06.2019	标准化 Stand.	-	-	-	-
All Dimensions in mm Original Size DIN A 4				工艺 Process	-	-	批准 Approved	HQ ZHANG	11.06.2019	

